

Intelligent Tunable White LED Driver (Constant Voltage)

- Small size and light weight. Adopt SAMSUNG/COVESTRO V0 flame resistant polycarbonate protective housings.
- The design of dismountable end cap allows you to adjust the length of housing depending on your needs.
- Dimming interfaces: DMX512/RDM, Push DIM/CCT.
- SELV output channel with common anode.
- Constant power design, adjust different color temperature to keep the same brightness.
- Supports RDM remote device management protocol.
- Dimming range: 0-100%, dimming down to 0.1%.
- With soft-on and fade in function, visual more comfortable.
- Color temperature range: 2700-6500K
- Flicker-free with high frequency exemption level in 0-100% dimming process.
- High-performance drivers: Efficiency 88%, PF>0.95, THD<8%.
- Comply with the EU's ErP Directive, stand-by power consumption<0.5W.
- The secure and reliable design for signal isolation.
- Innovative thermal management technology intelligently protects the lifetime the driver.
- Over-heat / Over voltage / Over load / Short circuit protection, recover automatically.
- Suitable for lamp applications of indoor I/II/III types.
- Up to 50000-hour life time.
- 5 year warranty (Rubycon Capacitor).

Flicker-free
IEEE 1789
Achieve high frequency exemption level.

Dimmable:
0.1%-100%

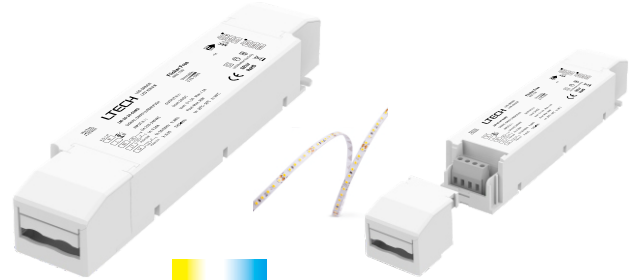

(The certification icons represent on-going certification applications only, and final certification qualification is subject to actual products.)



Technical Specs

Model		LM-36-24-G2M2	LM-36-12-G2M2	
OUTPUT	Output Voltage	24Vdc	12Vdc	
	Output Voltage Range	24Vdc ± 0.5Vdc	12Vdc ± 0.5Vdc	
	Output Current	Max. 1.5A	Max. 3A	
	Output Power	Max. 36W		
	Output Power Range	0-36W		
	Strobe Level	High frequency exemption level.		
	PWM Frequency	3600Hz		
	Dimming Range	0-100%, dimming down to 0.1%		
	Overload Power Limitation	≥ 102%		
Ripple & Noise	Switch ripple ≤ 200mV, noise ≤ 500mV	Switch ripple ≤ 200mV, noise ≤ 800mV		
INPUT	Dimming Interface	DMX512/RDM, Push DIM/CCT		
	Input Voltage	200-240Vdc / 200-280Vdc		
	Frequency	50/60Hz		
	Input Current	Max. 0.26A/230Vac		
	Power Factor	PF>0.95/230Vac, at full load		
	THD	<8% at 230Vac, at full load		
	Efficiency [typ.]	88%	87%	
	Standby Power Loss	<0.5W		
	Inrush Current[typ.]	Cold start 25A at 230Vac		
	Control Surge Capability	L-N:2KV		
Leakage Current	Max. 0.5mA			
ENVIRONMENT	Working Temperature	ta: -20°C ~ 50°C tc: 90°C		
	Working Humidity	20 ~ 95%RH, non-condensing		
	Storage Temperature Humidity	-40°C ~ 80°C, 10-95%RH		
	Temperature Coefficient	±0.03%/°C [-20-50°C]		
	Vibration	10-500Hz, 2G 12min./1cycle, 72 min for X, Y and Z axes respectively .		
PROTECTION	Over-heat Protection	Intelligently adjust or turn off the output current if the PCB temperature ≥110°C, recover automatically .		
	Over Voltage Protection	Shut down the output when non-load voltage ≥28V, re-power on to recover after fault condition is removed.	Shut down the output when non-load voltage ≥16V, re-power on to recover after fault condition is removed.	
	Over Load Protection	Shut down the output when current load ≥102%, recover automatically .		
	Short Circuit Protection	Enter hiccup mode if short circuit occurs, recover automatically .		
SAFETY & EMC	Withstand Voltage	I/P-O/P:3750Vac		
	Insulation Resistance	I/P-O/P:500Vdc/25°C/70%RH ≥ 100MΩ		
	Safety Standards	CCC	China	GB19510.1, GB19510.14
		TUV	Germany	EN61347-1, EN61347-2-13, EN62493
		CE	European Union	EN61347-1, EN61347-2-13, EN62384
		KC	Korea	KC61347-1, KC61347-2-13
		RCM	Australia	AS61347-1, AS61347-2-13
		ENEC	Europe	EN61347-1, EN61347-2-13, EN62384
		CB	CB member states	IEC61347-1, IEC61347-2-13
	EMC Emission	EAC	Russia	IEC61347-1, IEC61347-2-13
		CCC	China	GB/T17743, GB17625.1
		CE	European Union	EN55015, EN61000-3-2, EN61000-3-3, EN61547
		KC	Korea	KN15, KN61547
		RCM	Australia	EN55015, EN61000-3-2, EN61000-3-3, EN61547
EAC		Russia	IEC62493, IEC61547, EH55015	
EMC Immunity	EN61000-4-2,3,4,5,6,8,11, EN61547			
Strobe Test Standard	IEEE 1789			
OTHERS	Weight[G.W.]	210g±10g		
	Dimensions	210×43×30mm[L×W×H]		
	Package Size	213×44×33mm[L×W×H]		
	Carton Size	440×218×235mm[L×W×H] 60pcs/ctn 13.4kg±5%/ctn		

* The driver is suitable for connecting resistor current-limiting LED fixture (e.g. LED strip). The inrush current will be dozens of times increased if connecting built-in constant current IC current-limiting LED fixtures, the driver will activate the overloaded protection (hiccup flickering). When you order, please remark controlling the constant current LED fixture (e.g. MR16 lamp, underground light, LED wall washer, constant current LED strip, etc.), then we can prepare the special programs.

Product Size

Unit: mm

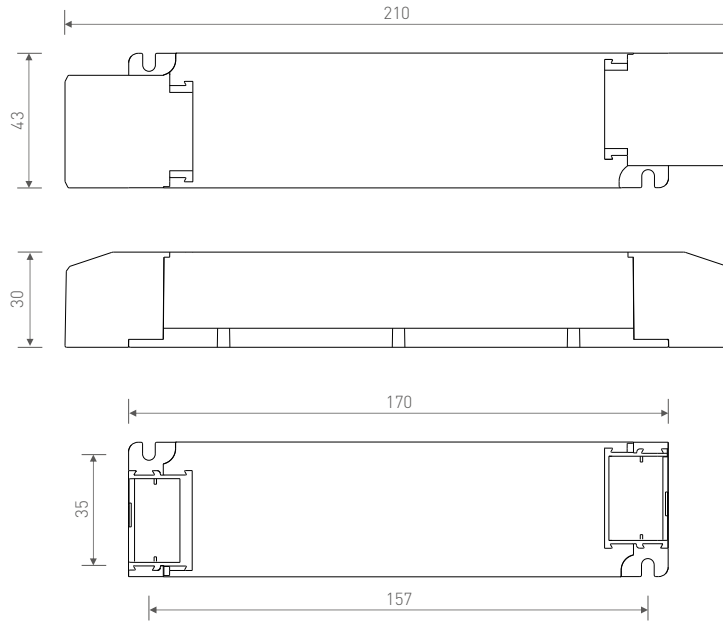

Wiring Diagram

DMX/RDM Connection Mode

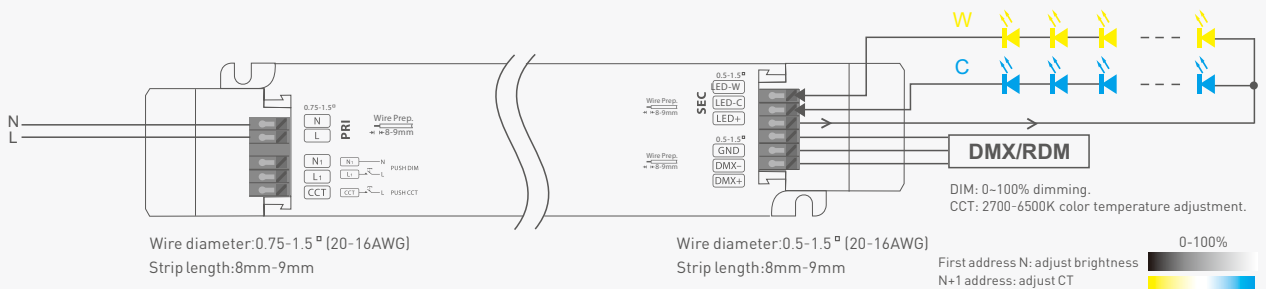

Push DIM/CCT Connection Mode

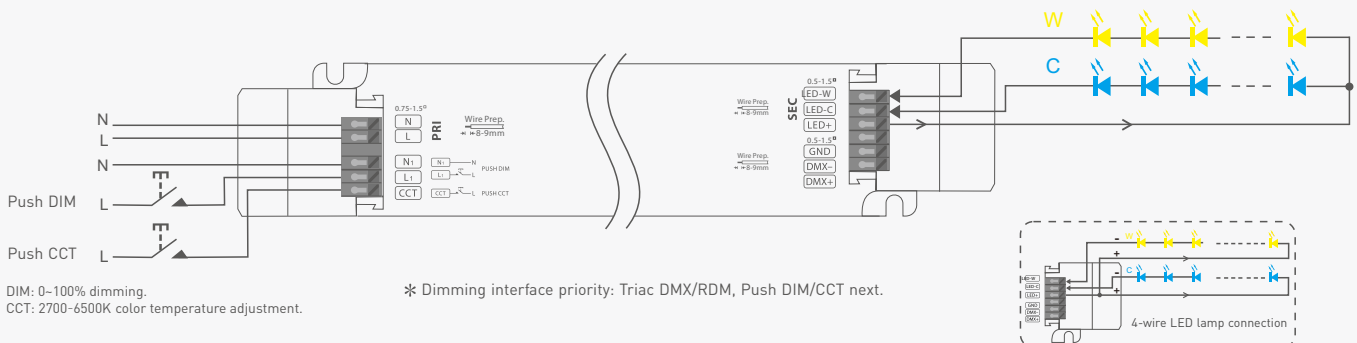

* With the constant power program design, brightness remains the same during color temperature adjustments. Drivers can be connected with the load twice the rated power. **36W drivers can be connected with the load of 36W × 2CH.** The total power of both channels keeps within 36W.

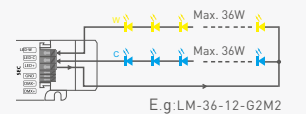

Push DIM



Reset switch

DIM

- On/off control: Short press.
- Stepless dimming: Long press.
- With every other long press, the brightness level goes to the opposite direction.
- Dimming memory: Go to the brightness level adjusted previously when lights are turned on.

CCT

- Color temperature adjustment: Long press.
- With every other long press, the color temperature level goes to the opposite direction.
- Color temperature memory: Color temperature will be the same as previously adjusted when turning off and on again.

Protective Housing Application Diagram

Tension plate

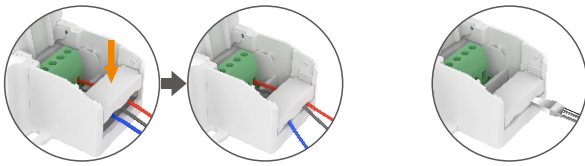

Push the tension plate down to fix the electric wires.

Push the side plate outwards and remove the tension plate by prying it up with a tool at the same time.

Remove the protective housing

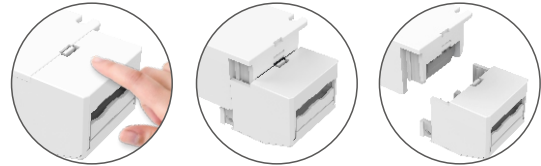

Pull the bottom left and right from the bottom to remove it.

Relationship Diagrams

Efficiency VS Load

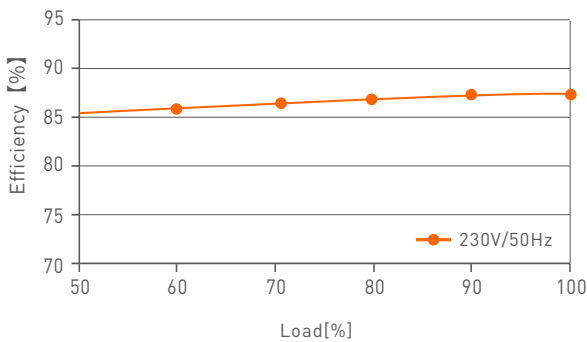

Power Factor Characteristic Curve

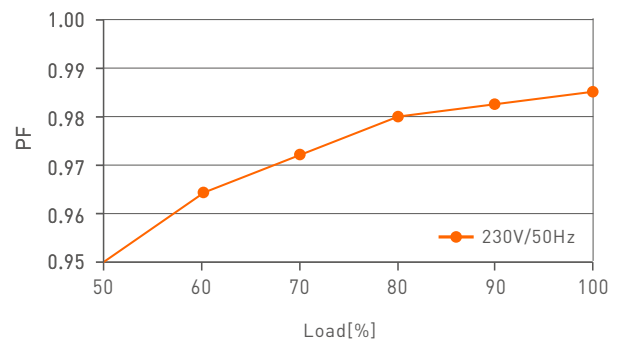

THD Characteristic Curve

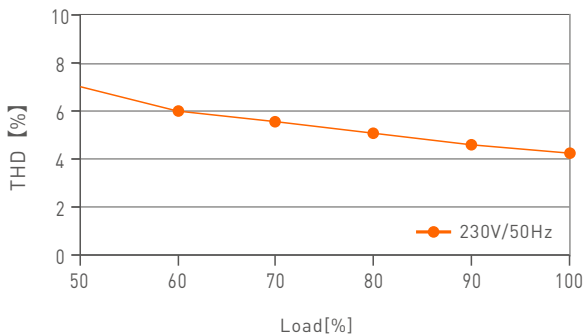

Over Load Diagram

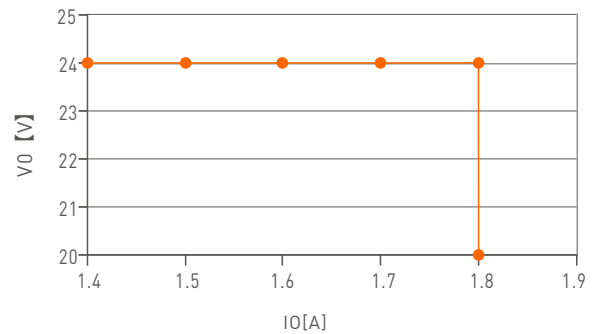

LM-36-24-G2M2

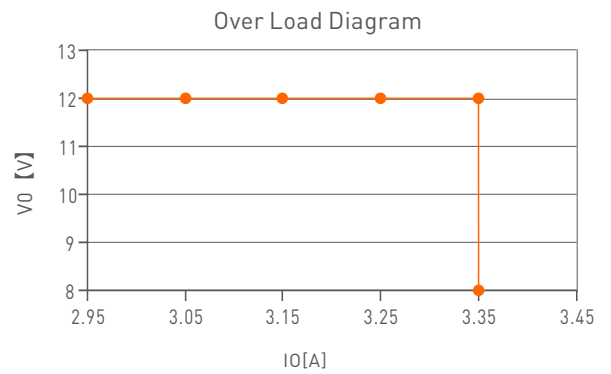
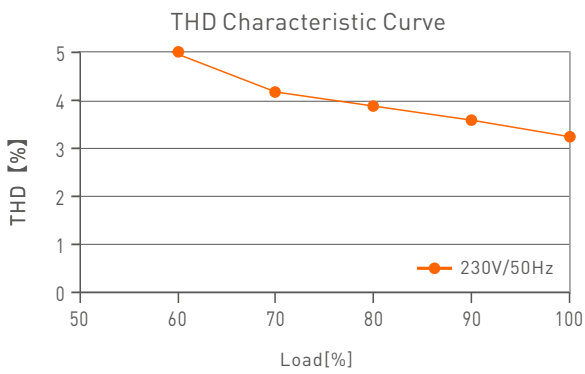
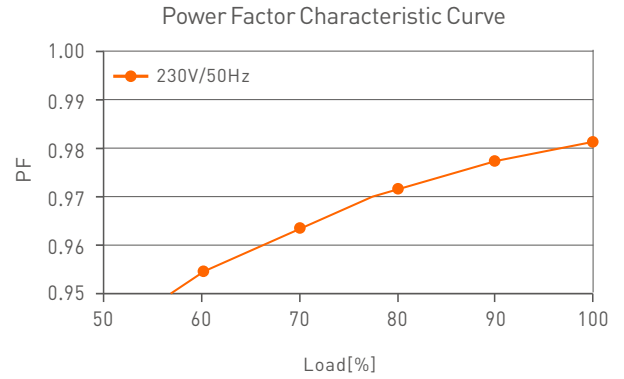
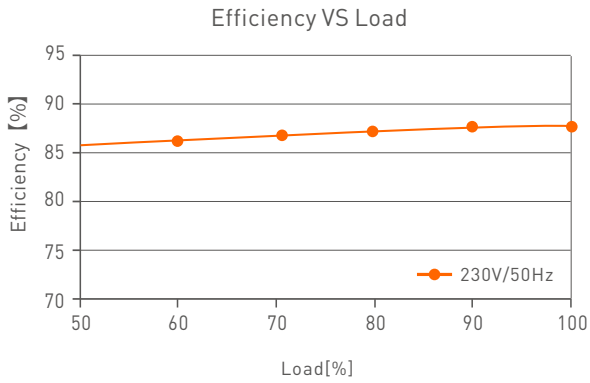

LM-36-12-G2M2

DMX Address Setting

The DMX driver can work with the address editor that complies with standard RDM protocol. It is recommended to use LTECH's RDM editor (model WiFi-RDM01), which can achieve more functions such as remote browsing and parameter setting. Wiring diagram as below:

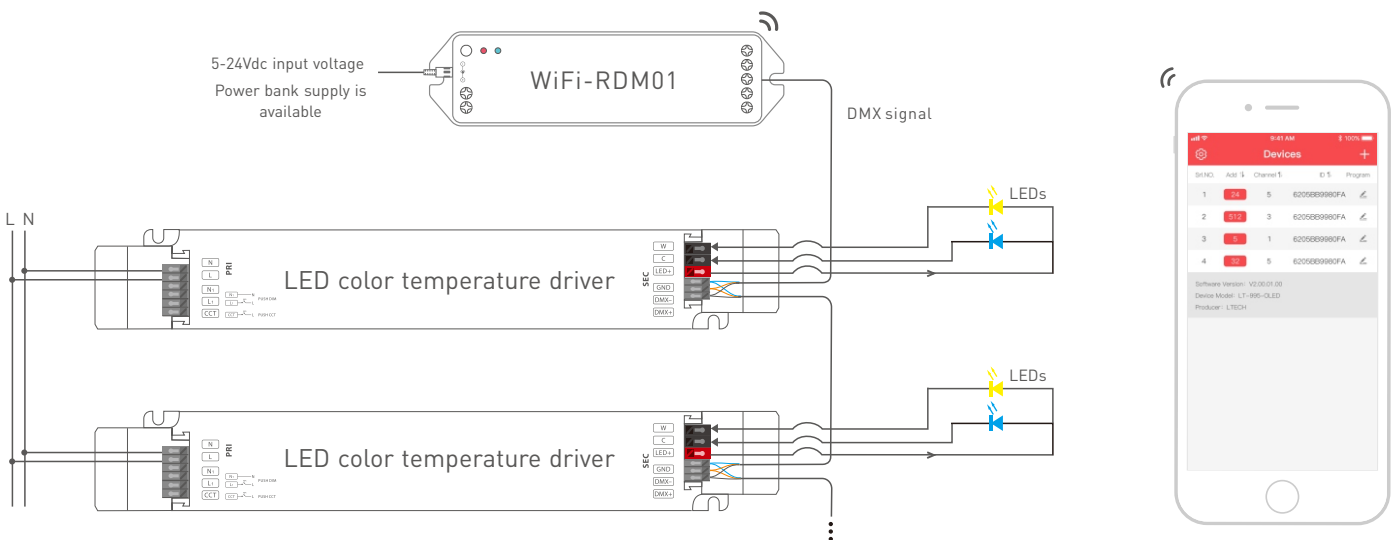

* the defaulted DMX address of the driver is 1.

LTECH RDM editor App interface instruction

Download the App, setting the parameters after well connecting the RDM editor, please check the manual of WiFi-RDM01 for more details.

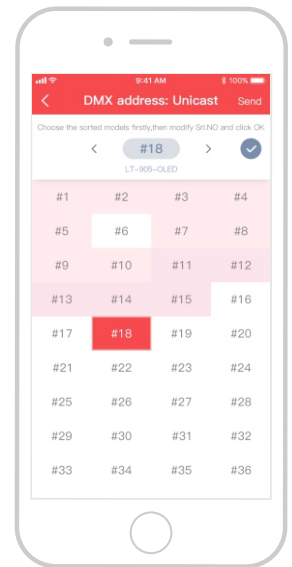
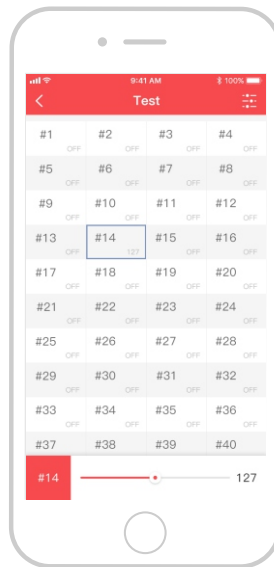
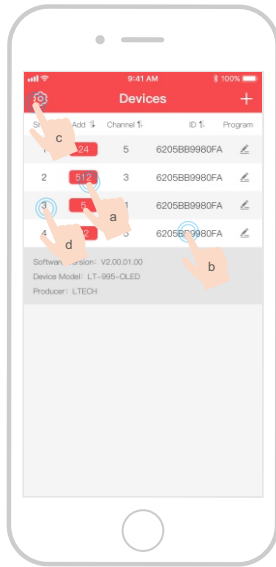

- a: Click "Add", edited the address in corresponding box.
- b: Click "ID", get more product details.
- c: Click "⚙️", enter setting interface
- d: Click "No.", issue the recognizing command.

Test

DMX address setting

Flicker Test Table

IEEE 1789

Limit Value of Modulation in Low Risk Areas	
Waveform frequency of Optical output	Limit value (%)
$f \leq 8\text{Hz}$	0.2
$8\text{Hz} < f \leq 90\text{Hz}$	$0.025 \times f$
$90\text{Hz} < f \leq 1250\text{Hz}$	$0.08 \times f$
$f > 1250\text{Hz}$	Exemption assessment
Limit Value of Modulation in No Effect Areas	
Waveform frequency of Optical output	Limit value (%)
$f \leq 10\text{Hz}$	0.1
$10\text{Hz} < f \leq 90\text{Hz}$	$0.01 \times f$
$90\text{Hz} < f \leq 3125\text{Hz}$	$(0.08/2.5) \times f$
$f > 3125\text{Hz}$	Exemption assessment (High frequency exemption)

- Brightness
- ▲ 0.1%
 - ◆ 1%
 - ▲ 5%
 - ◆ 10%
 - 20%
 - ▲ 30%
 - 40%
 - ★ 50%
 - 60%
 - 70%
 - 80%
 - ★ 90%
 - ◆ 100%

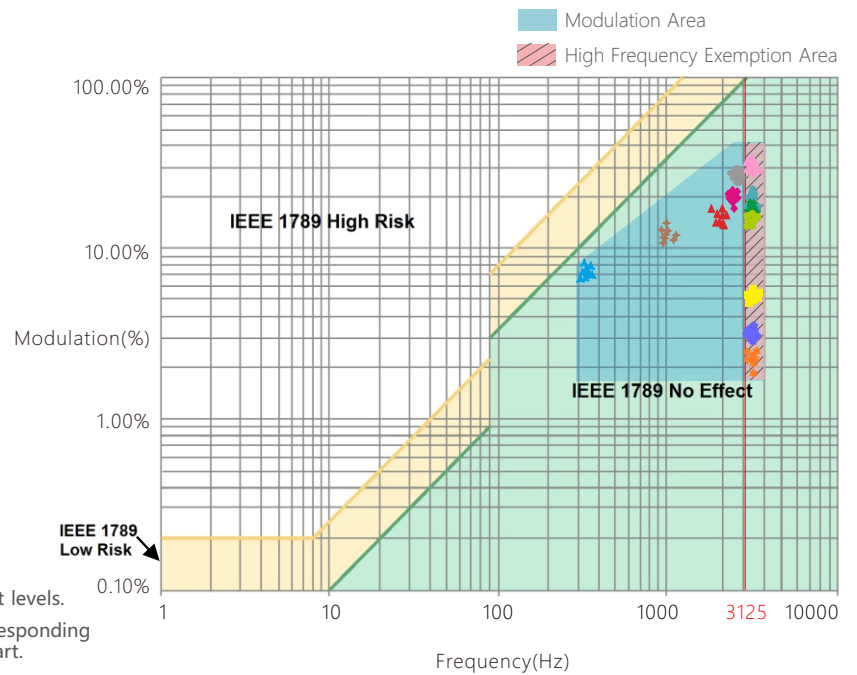

Marks in the right chart are tested results of different current levels.
The output frequency is 0Hz in 100% brightness and its corresponding modulation is 0%, which could not be shown in the right chart.

Attentions

- Products shall be installed by qualified professionals.
- LTECH products are non-waterproof (special models excepted). Please avoid the sun and rain. When installed outdoors, please ensure it is mounted in a water proof enclosure.
- Good heat dissipation will extend the working life of products. Please ensure good ventilation.
- Please check if the working voltage used complies with the parameter requirements of products.
- The diameter of wire used must be able to load the light fixtures you connect and ensure the firm wiring.
- Before you power on products, please make sure all the wiring is correct in case of incorrect connection that causes damage to light fixtures.
- If a fault occurs, please do not attempt to fix products by yourself. If you have any question, please contact your suppliers.

* This manual is subject to changes without further notice. Product functions depend on the goods. Please feel free to contact our official distributors if you have any question.

Warranty Agreement

- Warranty periods from the date of delivery : 5 years.
- Free repair or replacement services for quality problems are provided within warranty periods.

Warranty exclusions below:

- Beyond warranty periods.
 - Any artificial damage caused by high voltage, overload, or improper operations.
 - Products with severe physical damage.
 - Damage caused by natural disasters and force majeure.
 - Warranty labels and barcodes have been damaged.
 - No any contract signed by LTECH.
1. Repair or replacement provided is the only remedy for customers. LTECH is not liable for any incidental or consequential damage unless it is within the law.
 2. LTECH has the right to amend or adjust the terms of this warranty, and release in written form shall prevail.

Update Log

Version	Updated Time	Update Content	Updated by
A0	2021.03.22	Original version	Xu Shujun